

DRAGLINE BUCKET AND RIGGING

Maximise productivity through reduced weight,
maximum payloads and increased uptime.

Global leader in dragline buckets

- Market-leading Hurricane™ bucket family
- Individually tailored suite of dragline buckets and specialised rigging

THE MOST ADVANCED PRODUCTIVITY SOLUTIONS

Leaders in innovation.

We are the leader in dragline bucket innovation, delivering step changes in productivity with every new generation bucket delivered to dragline mining operations. Through our unique scale-testing facility located at our Technology Park, combined with dragline production data monitoring software and analysis, CR Powered by Epiroc's patented, best practice designs reduce weight, increase payload and increase availability for dragline operations around the world.

Our designs allow our engineering products team to collaborate with you to deliver a bucket to maximise the productivity of your dragline, in any mining conditions. With sizes available for all applications—from small to XL class dragline machines, we have a combination of dragline bucket, GET and rigging to suit the most demanding operations.



Lower energy consumption by 19%

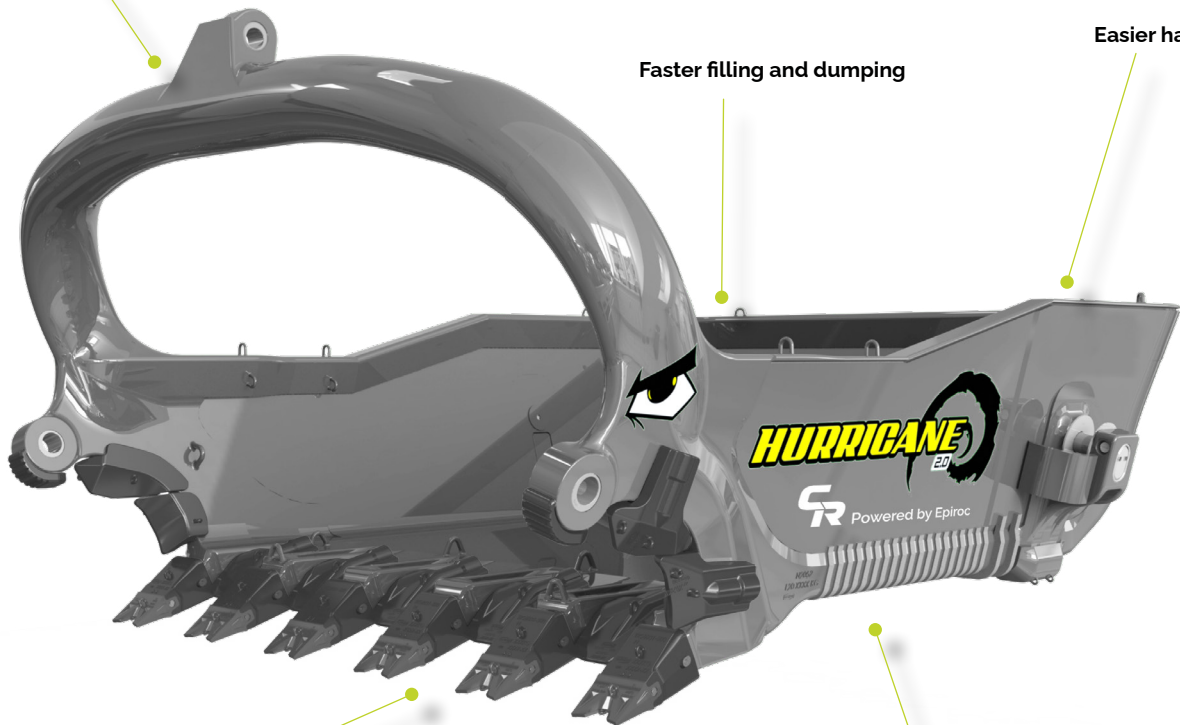

Faster filling and dumping

Easier handling

Lower rebuild costs

Robust and reliable design

HURRICANE™

Industry standard

Launched in 2007, our Hurricane dragline bucket represents the industry standard in bucket design and technology. The Hurricane is a fast-filling, consistent and high-efficiency dragline bucket.

With its patented, wide, low profile and slimline lip design, the Hurricane also provides substantial energy savings of 19% due to reduced drag energy when compared to traditional shaped dragline buckets.





HURRICANE™ 2.0

Next-generation performance

The Hurricane 2.0 dragline bucket delivers productivity gains of over 16% compared to conventional dragline buckets.

With over 30 years of industry-leading dragline knowledge and millions of cycles of dragline data, we've achieved the next generation of Hurricane performance to drive mining efficiency. Hurricane 2.0 is the most technically advanced dragline bucket the industry has ever seen.

Talk to us about how you can achieve the best performance for your machine.

<p>BUCKET OPTIONS TO SUIT</p>	 <p>S</p>	 <p>M</p>	 <p>L</p>	 <p>XL</p>
<p>MANUFACTURER MODELS</p>	<p>CAT 8050 KOMATSU 757</p>	<p>CAT 8200 KOMATSU 9010</p>	<p>CAT 8750 KOMATSU 9020C</p>	<p>CAT 8750+ KOMATSU 9020XPC</p>

Dragline Rigging

Our rigging components work together to reduce your mine site's downtime and costs while maximising machine performance. We have a comprehensive range of dragline rigging components designed and engineered to endure harsh operating conditions, while minimising weight.

The advanced alloy steel and design integrity of our rigging deliver quantifiable production improvements and reduced downtime for customers.

With more than 250 dragline buckets delivered globally, we have the experience, data and resources required to maximise your dragline's productivity.

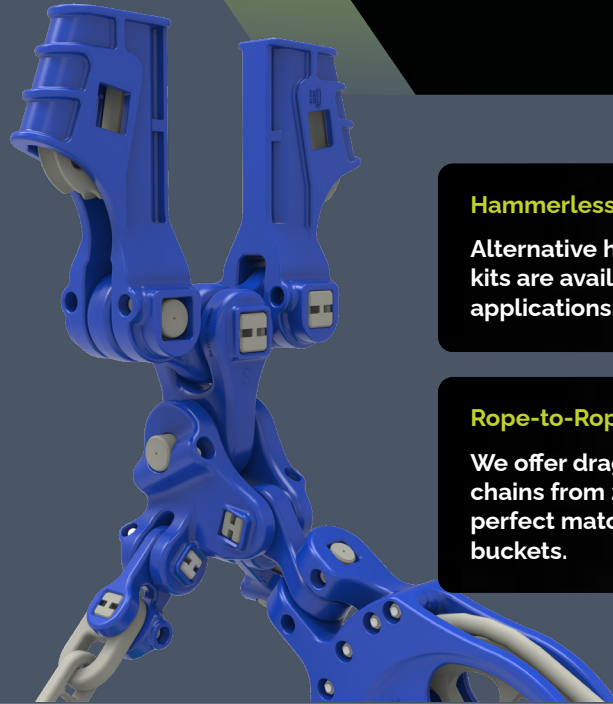

Hammerless Locking Kits

Alternative hammerless locking kits are available to suit your applications.

Rope-to-Rope System

We offer drag, dump and hoist chains from 2.5" to 5" in size, a perfect match to our rigging and buckets.

Hurricane dragline bucket with rigging

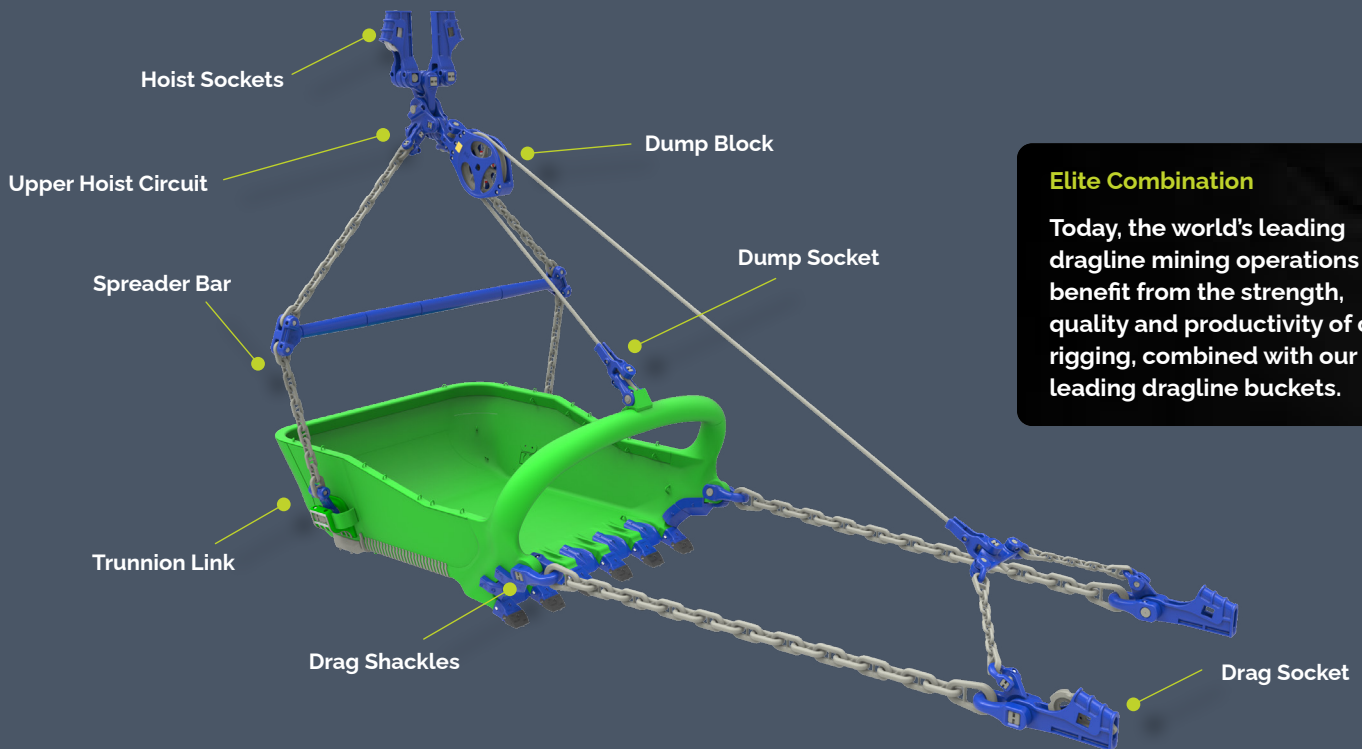

Elite Combination

Today, the world's leading dragline mining operations benefit from the strength, quality and productivity of our rigging, combined with our leading dragline buckets.

CR Powered by Epiroc is on a mission to revolutionize mining productivity.

We engineer the most advanced surface and underground mining solutions for the world's best miners to unlock productivity, enhance safety, and reduce emissions.

Start the conversation

 (+61) 1800 987 525

 Globalsales@crmining.com

 (+1) 866 276 4637

 crmining.com