

TITAN 3330™

LOAD HAUL OPTIMIZATION

Reduce CO2e emissions and gain tangible real-time productivity



Titan 3330 enables you to:

- Reduce truck payload variance
- Increase average payload
- Reduce safety overloads
- Improve production across an optimized load haul fleet
- Reduce emissions by ensuring trucks are carrying target payload



INCREASE PAYLOAD & REDUCE DAMAGE

Real-time data—accurate loads.

The intuitive user interface displays real-time data that enables the operator to load trucks more accurately. By measuring truck payloads in real-time with payload monitoring, and the cumulative payload in the truck, the operator can adjust subsequent buckets to more closely achieve the truck target payload.

Titan 3330 enables specific payload targets be set for individual trucks. The targets allow mines to align their haul truck payloads with the site's production strategy, optimizing the load haul fleet.



Lower Emissions

Titan 3330 cuts fuel burn and CO₂e emissions by optimizing truck fill factor and minimizing over/underloads for the same tonnage mined.

Titan 3330 increased the median truck fleet payload for one miner from 227 to 239 tonnes, reducing diesel litres/tonnes by 0.8%. Over 10 million tonnes/year were additionally moved by the same fleet. That's the equivalent of a 1.3 million-litre pa diesel saving, equal to 3,500 tonnes CO₂e/year.

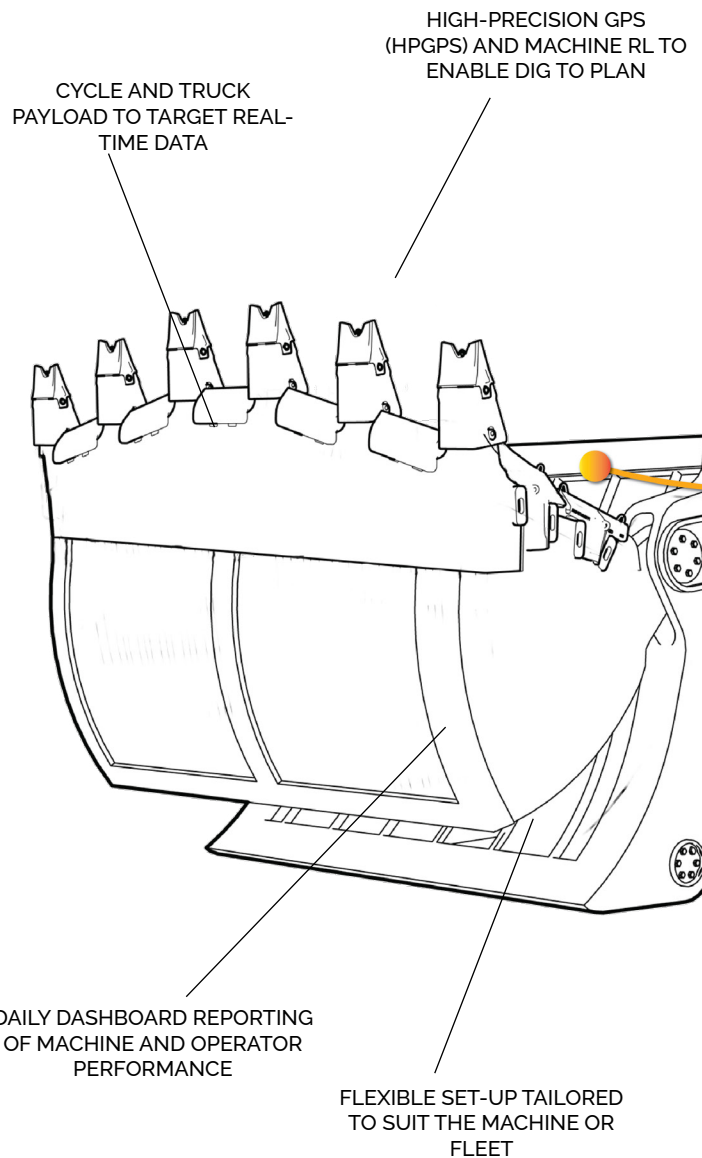
Titan may save up to 429 tonnes/pa CO₂e for the same ROM production.



ONE SYSTEM FOR DIFFERENT EQUIPMENT		
Face Shovel	Backhoe	Wheel Loader
		

- ✓ AI-powered payload monitoring – our most advanced real-time system ever
- ✓ New Truck Trakka technology – identifying trucks accurately
- ✓ Evolved user experience – Now more intuitive than ever
- ✓ Robust architecture developed for the future
- ✓ Real-time data enabling data-driven decisions
- ✓ One system, one software for your entire loading fleet
- ✓ Data leads to knowledge, and knowledge leads to power to continuously improve
- ✓ Our leading hardware platform – reliable, tough, small, built for mining

DUTY MONITORING OF THE BOOM AND STICK STRUCTURES

INTUITIVE IN-CAB OPERATING SYSTEM, PROVIDING REAL-TIME FEEDBACK AND REPORTING

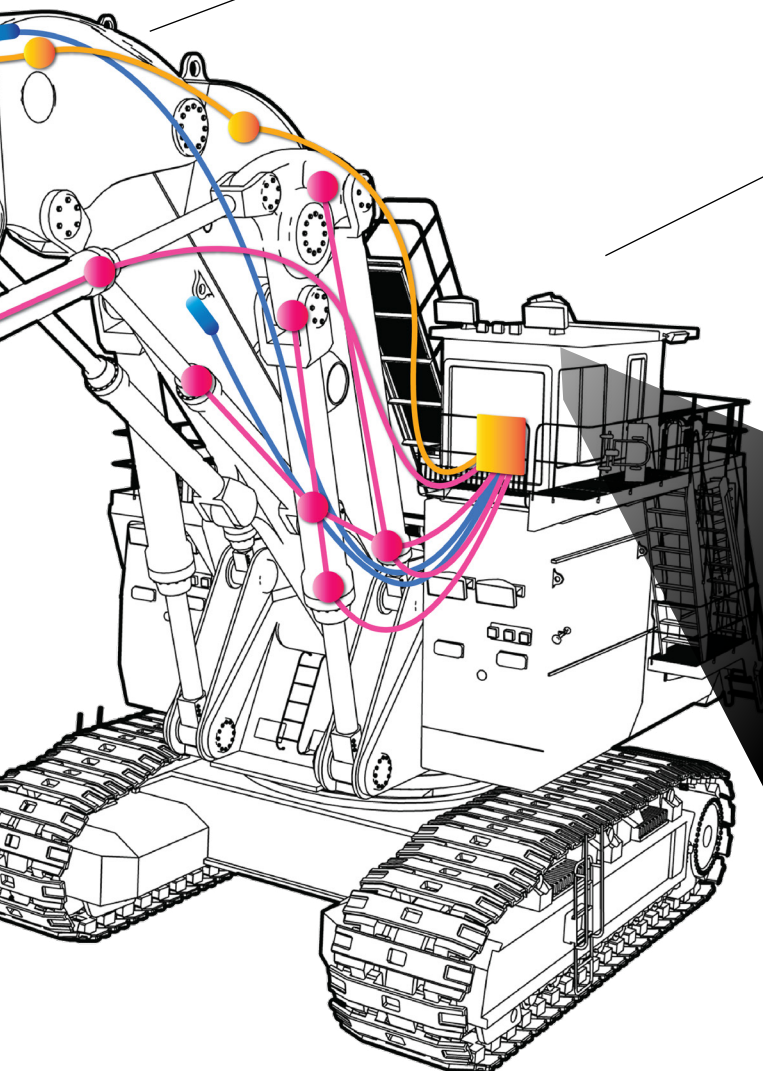

SIMPLE, INTUITIVE USER INTERFACE (UI)

Orion Data Analytics provides information from data, enabling ongoing, effective analysis of operational performance.

Our Analysis and Improvement service is a collaborative process that develops an understanding of the operational context for the information and supports joint identification of operational issues and improvement initiatives, generating actual knowledge and enabling continuous improvement.

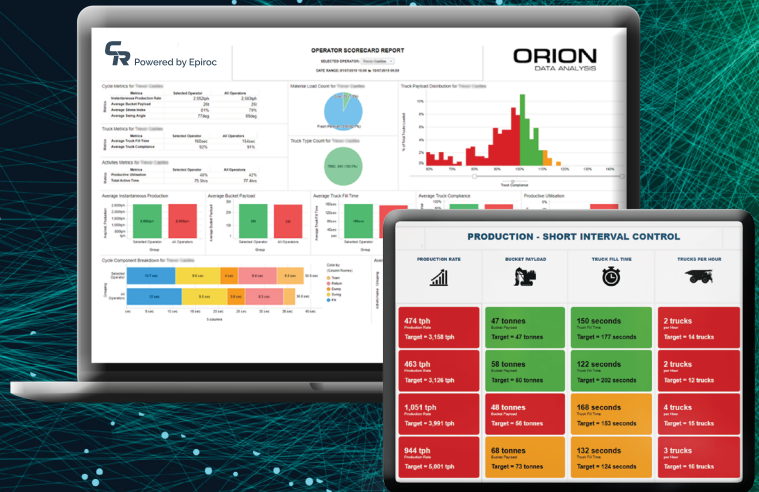

ORION

TITAN 3330

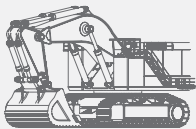

THUNDERBIRD 1110
DRILL OPTIMIZATION



GET TRAKKA
GET LOSS DETECTION

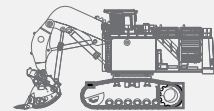

Orion Data Analysis and Improvement reporting delivers



Automated, compiled and distributed reports



Insights via web or mobile platforms



Short-term Interval Control and On-Demand Reports

CR Powered by Epiroc is transforming mines with cutting-edge technology.

We develop industry-leading digital technology solutions for the mining industry, working together with the world's best miners towards a safer, more productive, and sustainable future.

Start the conversation

(+61) 1300 338 482

Globalsales@crmining.com

(+1) 800 872 5099

crmining.com